



# Adaptive Compensation for Interleaving Artefacts in Multi-Converter ADCs for Radio Astronomy

Samantha Gordon and John Tuthill

Australia's National Science Agency



# Analogue to digital converter (ADC)



- Convert “real-world” analogue signals into discrete digital signals that can be used for further processing
- Limited by how fast it can complete the conversion

# Time-Interleaved ADCs to increase sample rate

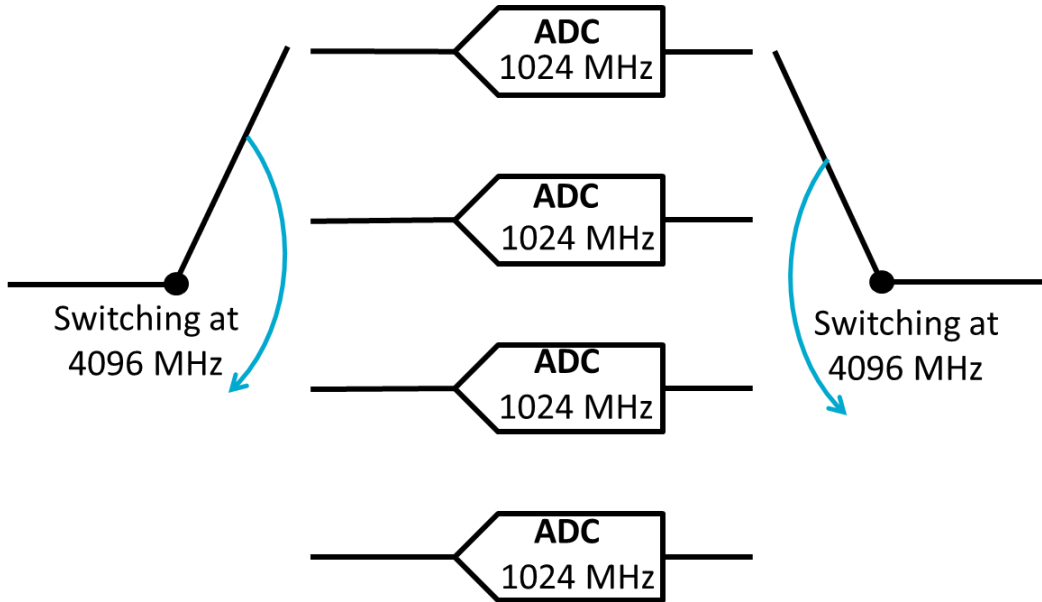

- Time-interleaving ADCs to increase sample rate while maintaining high resolution (effective number of bits)

[Black & Hodges, Time Interleaved Converter Arrays, IEEE J. Solid-State Circuits, 1980]

# Errors in interleaving ADCs

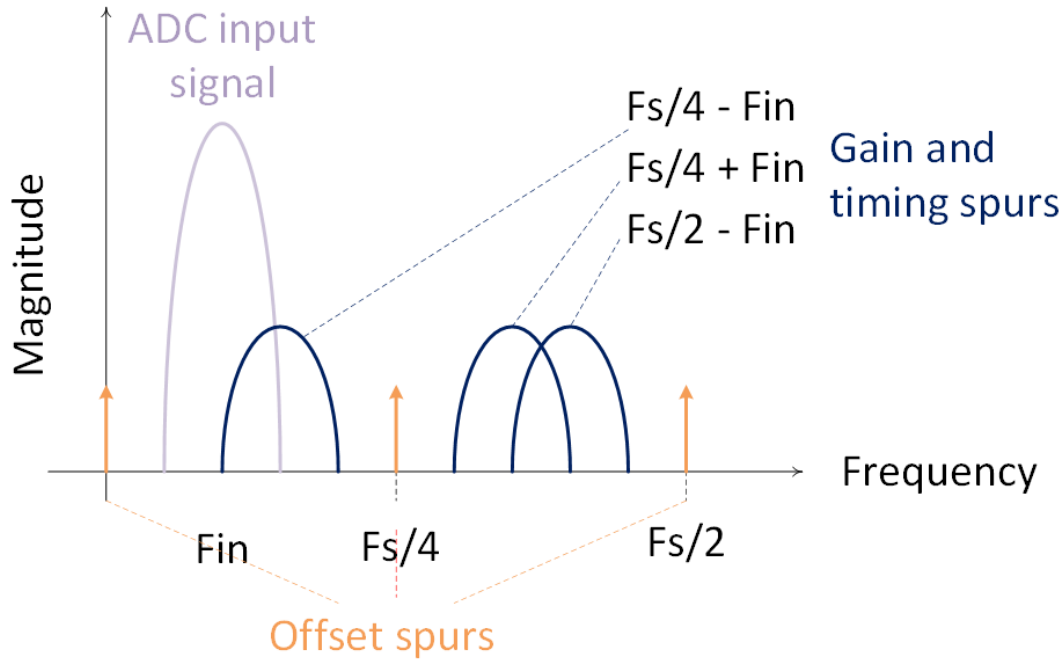

- Imperfections in interleaving ADCs introduce artefacts in resulting spectrum

# Time-interleaved ADC error sources

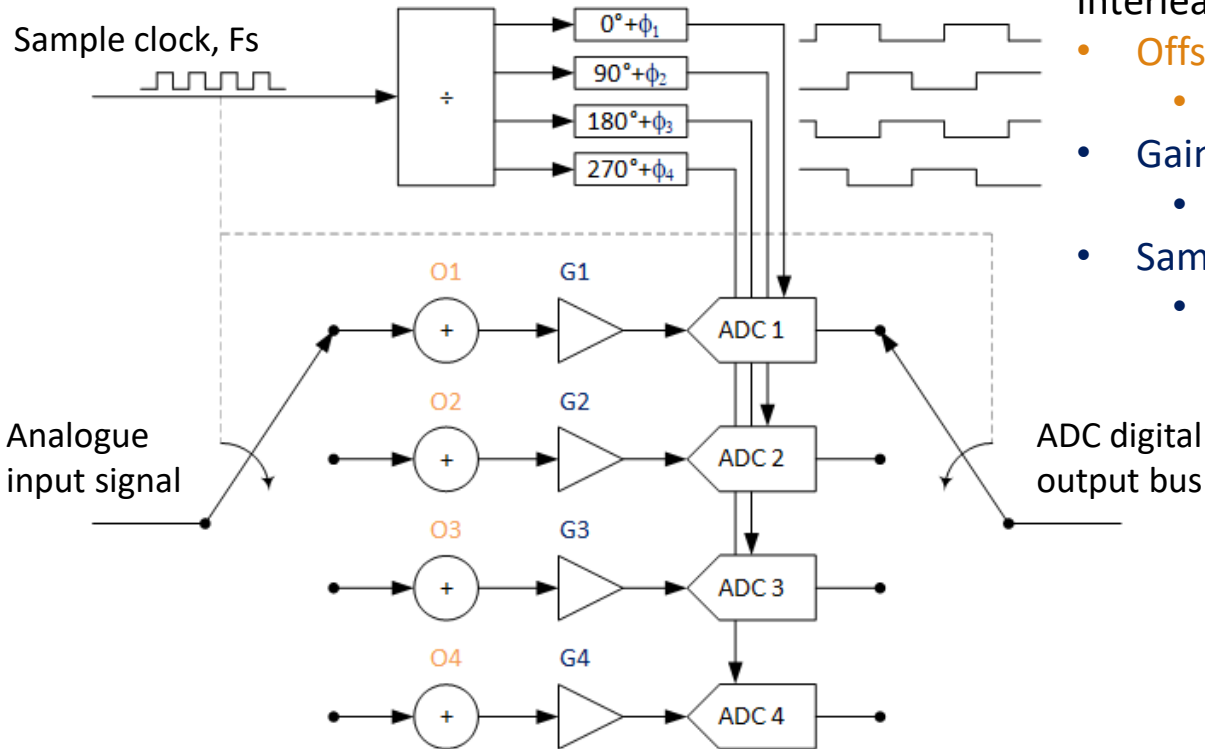

Interleaving errors:

- Offset mismatch ( $O_1 \neq O_2 \neq O_3 \neq O_4$ )
  - "offset spurs" at DC,  $F_s/4$  and  $F_s/2$
- Gain mismatch ( $G_1 \neq G_2 \neq G_3 \neq G_4$ )
  - "gain spurs" at  $F_s/4 \pm F_{in}$ ,  $F_s/2 + F_{in}$
- Sample time skew ( $\phi_1 \neq \phi_2 \neq \phi_3 \neq \phi_4$ )
  - "timing spurs" at  $F_s/4 \pm F_{in}$ ,  $F_s/2 + F_{in}$

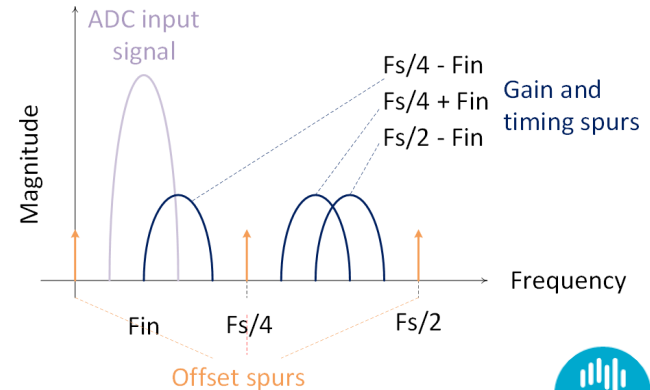

# ADC interleaving artefacts from strong RFI

- Strong RFI from a nearby telecommunications tower results in interleaving artefacts within the Parkes Radio Telescope (Murriyang)

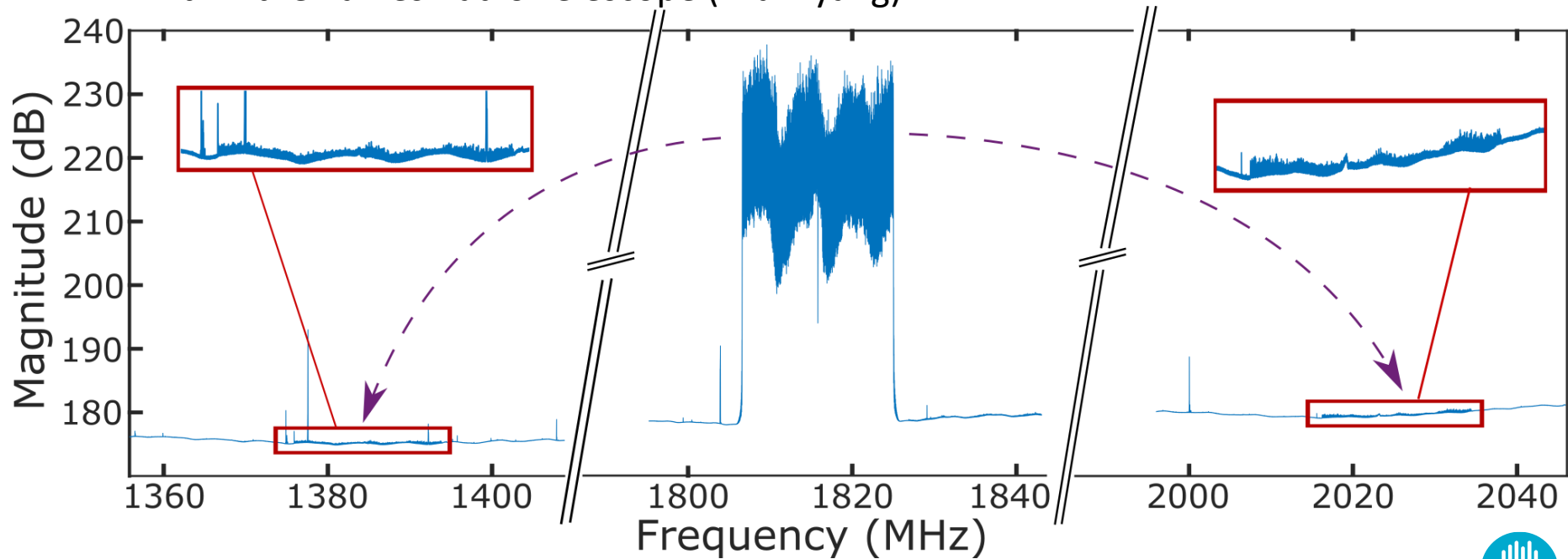

# Simulation: ADC-generated RFI

$F_s = 4096$  MHz  
 $f_{in}$  (centre) = 745 MHz  
Tone freq = 280 MHz

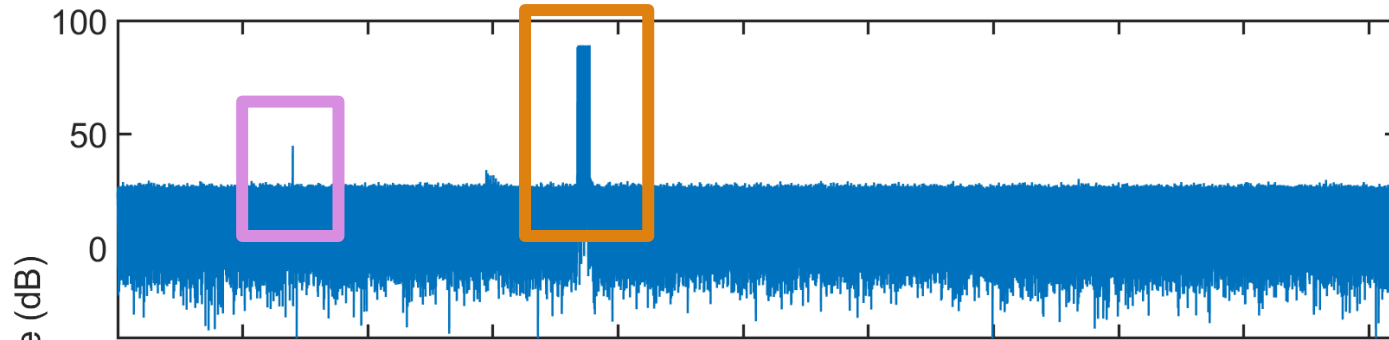

**No error**

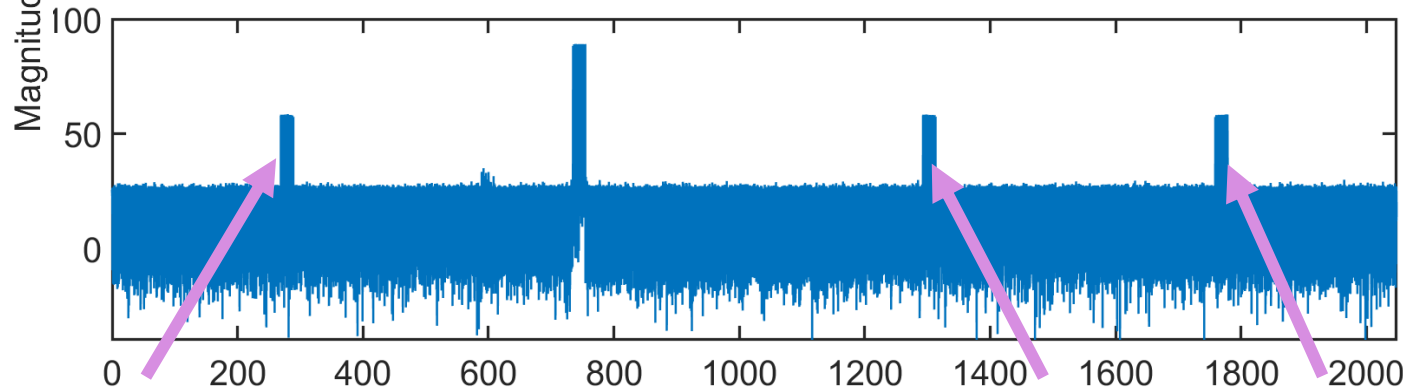

**10% timing error**

$$\frac{F_s}{4} - f_{in}$$

$$\frac{F_s}{2} - f_{in}$$

$$\frac{F_s}{4} + f_{in}$$

# Parkes Ultrawideband receiver signal chain

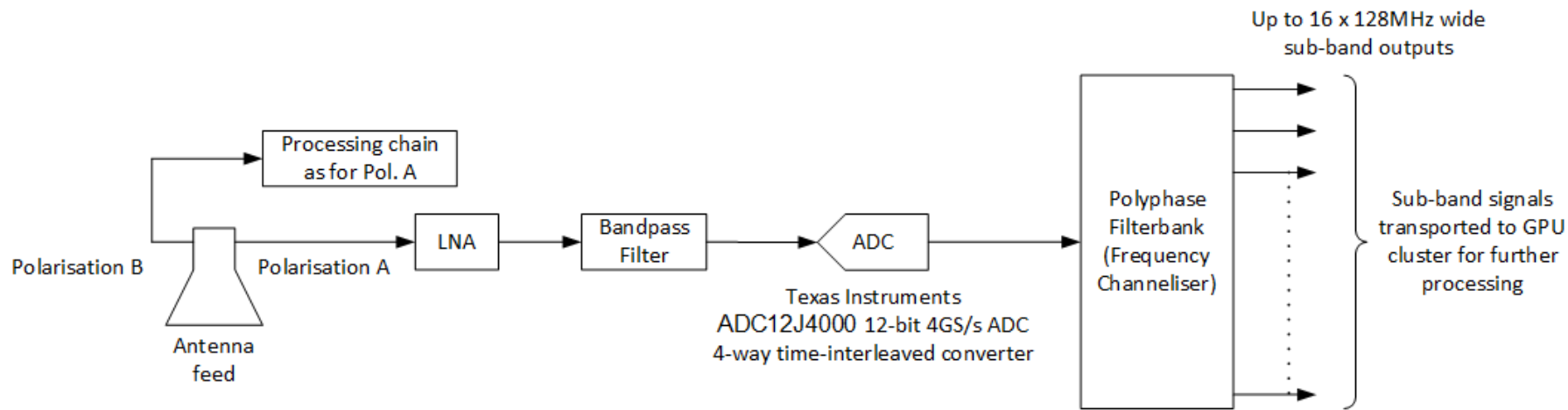

- Published artefact reduction algorithms (eg. Saleem and Vogel, 2011) require direct ADC output
- Our algorithm works with channelised output

# Adaptive compensation with an LMS interference canceller

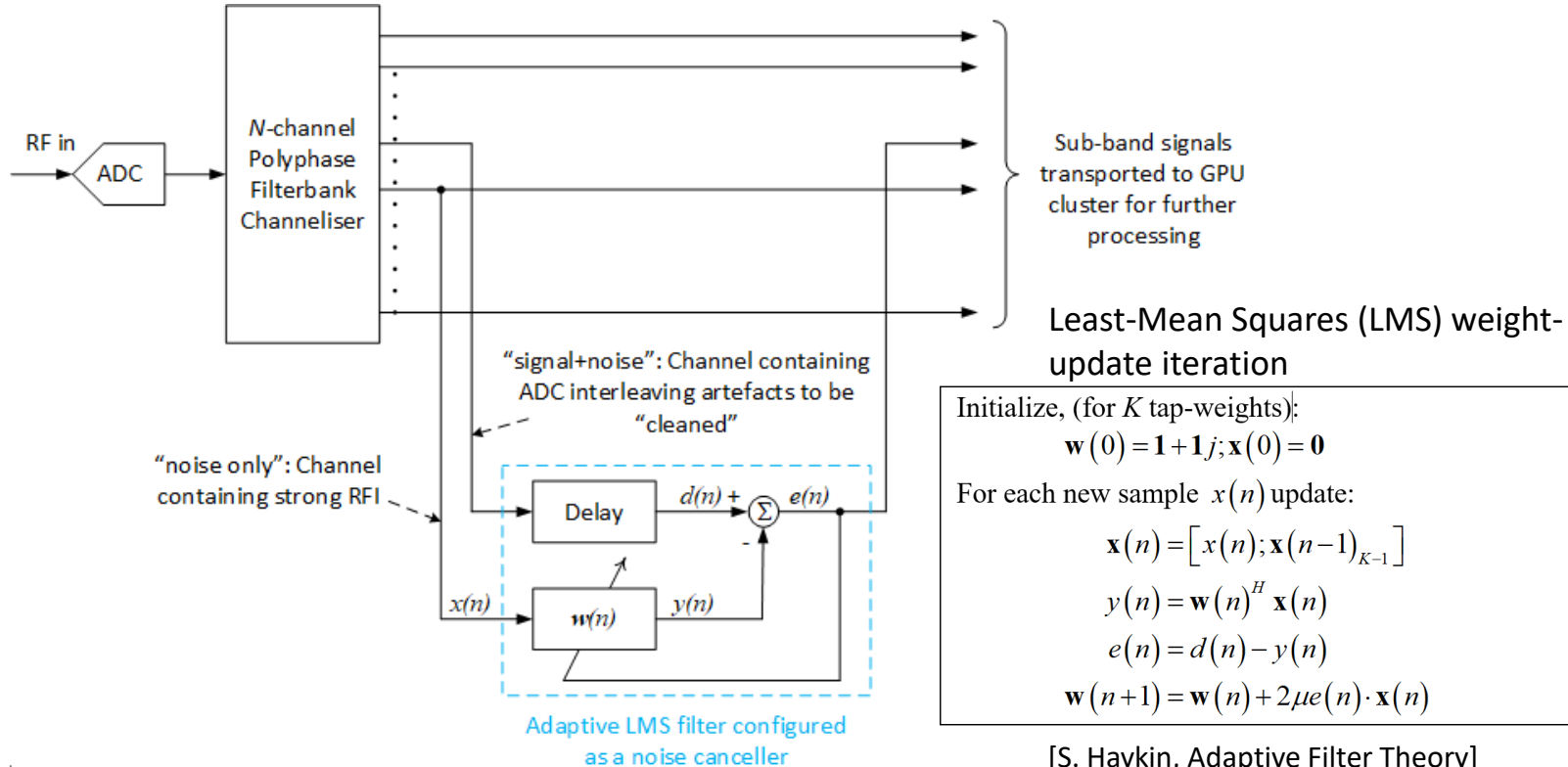

# Simulation: Results of adaptive compensation

$F_s = 4096$  MHz

$F_{in}(\text{centre}) = 745$  MHz

Tone freq = 280MHz

Timing error = 10%

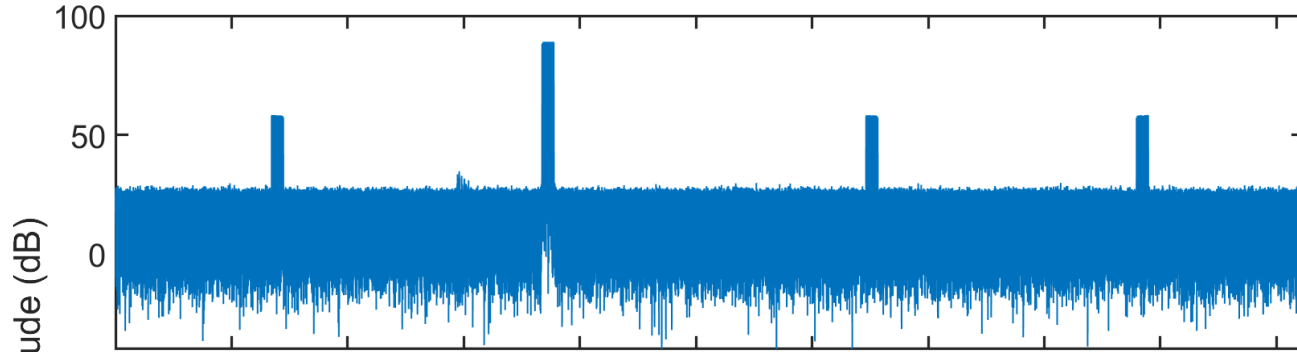

**Before Compensation**

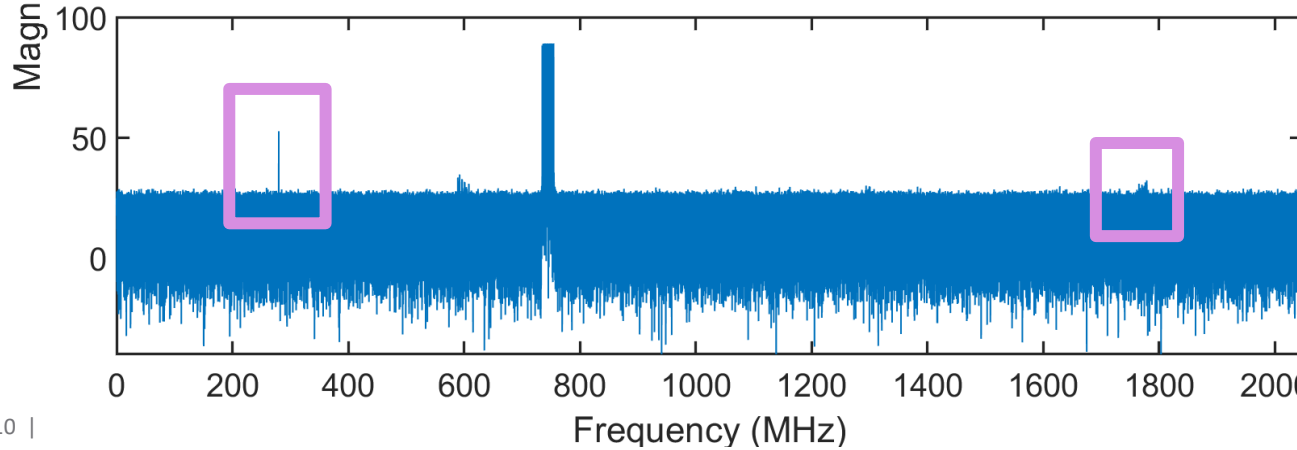

**After Compensation**

20 dB reduction for  
this configuration

# Some results from Parkes UWL system

Spectrum results obtained using DSPSR

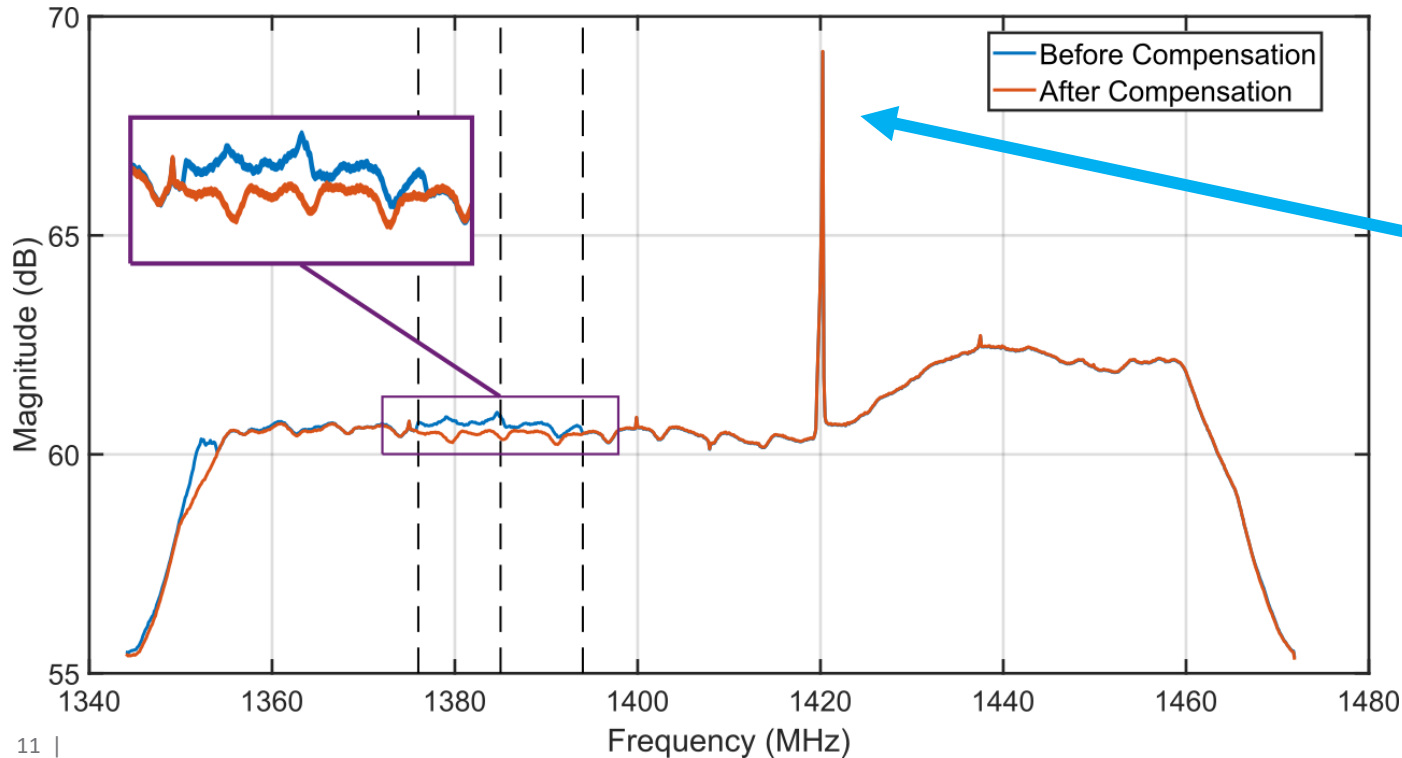

H1 line from our galaxy

# Demonstration of artificially introduced small tone

Artificially introduced tone still present after LMS compensation (**note** that this would have been undetectable prior to compensation)

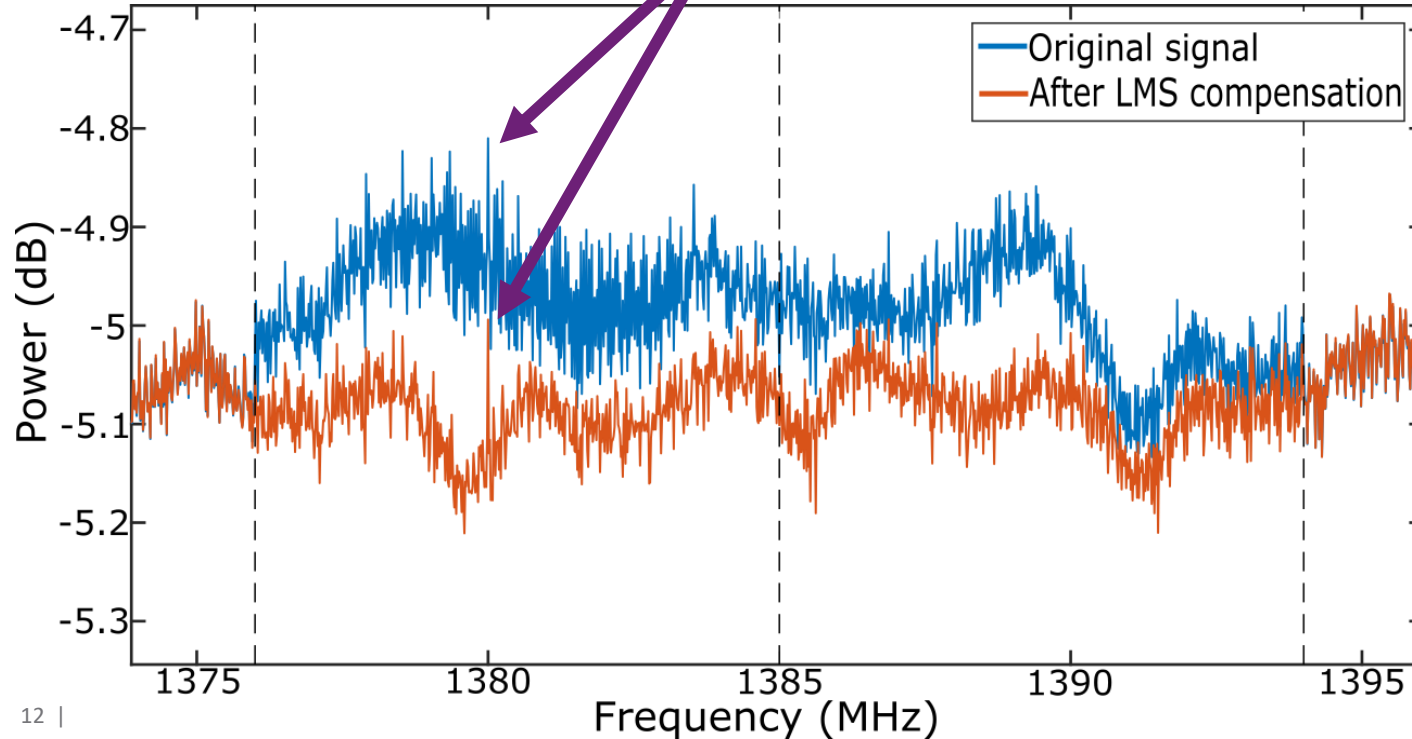

# Some results from Parkes UWL system

Pulsar folding using DSPSR

**Before compensation**

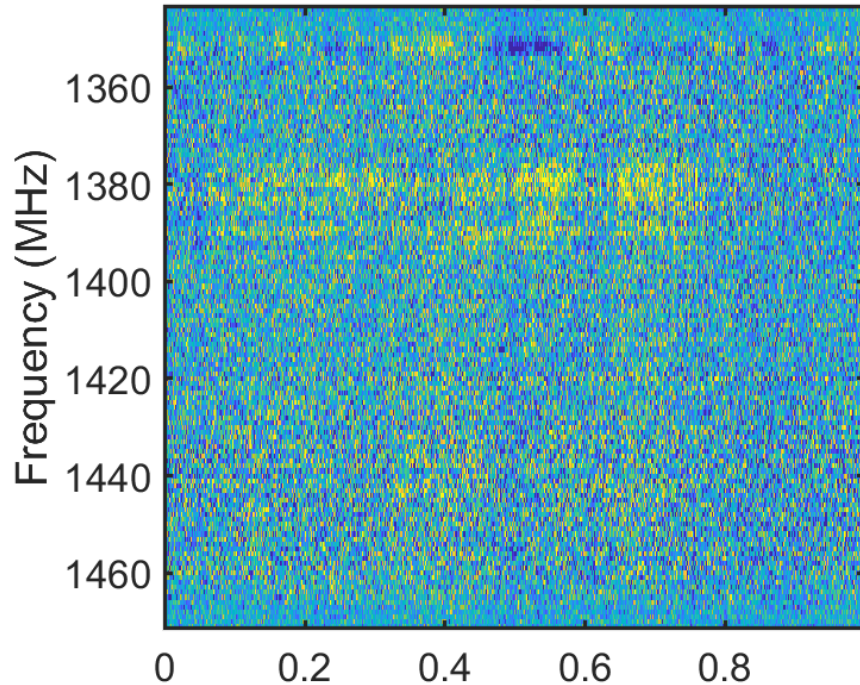

**After compensation**

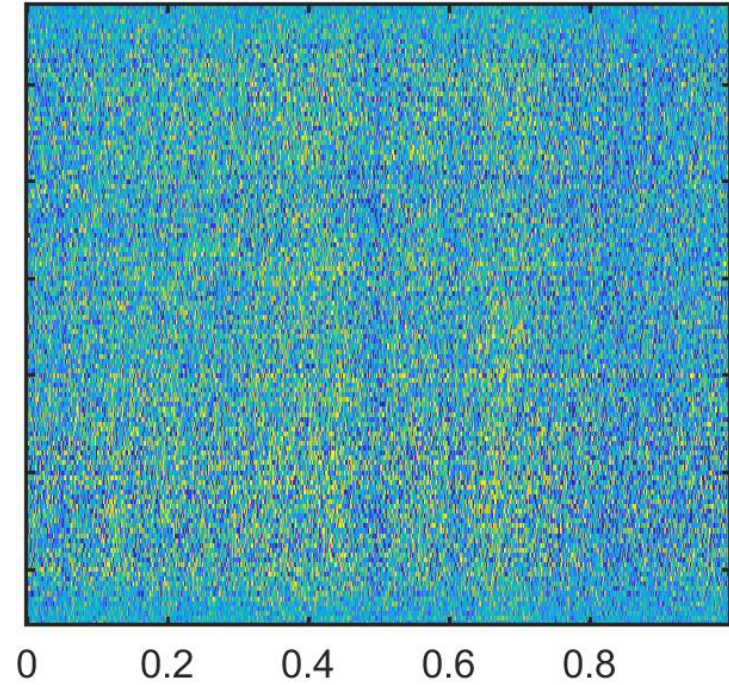

# Conclusions & Discussion

- LMS is effective at removing ADC interleaving artefacts (important for spectral line observing)
- Two filter taps performed best
- Performance improves as SNR increases
- Currently working on FPGA implementation for real-time compensation

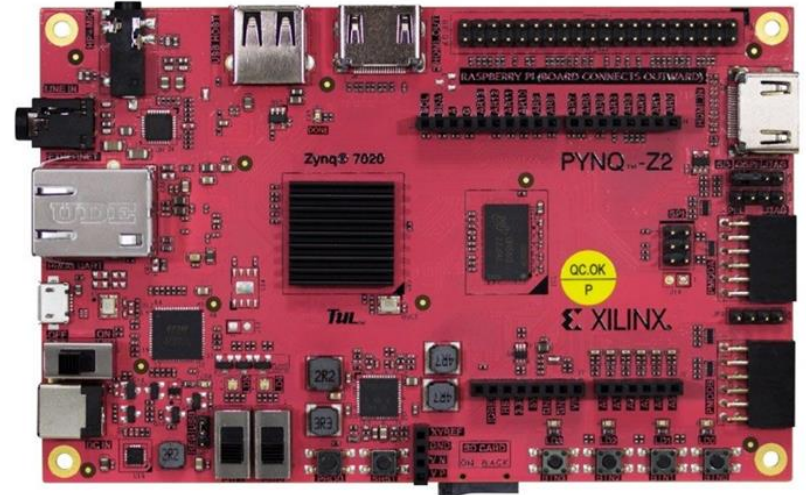

Image: Adafruit

# Thank you

## **Supervisors:**

John Tuthill (CSIRO Space and Astronomy)

Tara Murphy (University of Sydney)

## **Presenter:**

Samantha Gordon

CSIRO Space and Astronomy

University of Sydney

[sgor5338@uni.sydney.edu.au](mailto:sgor5338@uni.sydney.edu.au)

